

MONA180

Permanent Magnet Synchronous Gearless Traction Machine

永磁同步无齿轮曳引机

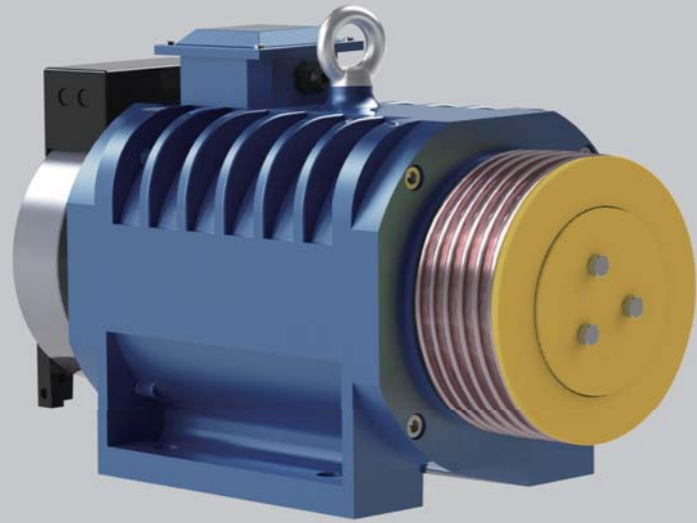

电源电压	Voltage	220V / 380V	曳引比	Roping	2:1
额定载重	Elv.Load	(320~630)kg	额定梯速	Elv.Speed	(0.4~1.0)m/s
曳引轮节径	Sheave Diam	180mm	工作制	Duty	S5-40%
防护等级	IP Code	IP41	最大轴静载	Max. Static Load	2500kg
绝缘等级	Ins.Class	F	自重	Weight	140kg
制动器	Brake	DC110V 2.4A			

※ 制动器的电压值表示启动及维持电压。 Brake voltage corresponds to its Start&Sustaining voltage.

安装尺寸图 DIMENSIONS

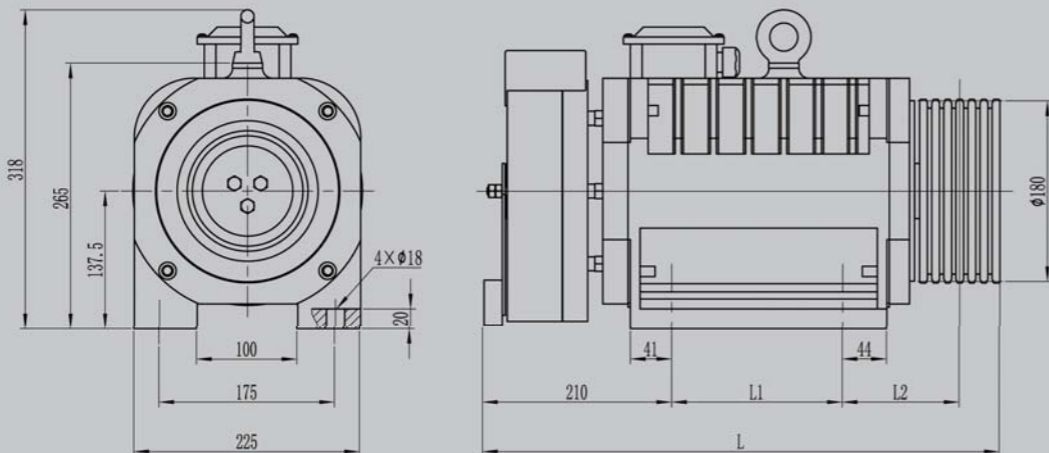

规格表 SPEC.SHEET

型号	规格	额定载重	额定梯速	曳引轮节径	曳引绳槽	电源电压	额定电流	额定功率	额定转速	额定频率	额定转矩	电机极数	L	L1	L2	切口角
Type	Spec.	Elv. Load	Elv. Speed	Sheave Dia.	Sheave Groove	Voltage	Current	Power	Speed	Freq.	Torque	Poles				β Angle
		kg	m/s	mm		V	A	kW	r/min	Hz	N·m		mm	mm	mm	°
MONA180	320-0.4	320	0.4	180	4×Φ6×12	220	6	0.9	85	11.3	100	16	515	150	116.5	
						380	4									
MONA180	320-0.5	320	0.5	180	4×Φ6×12	220	6	1.1	106	14.1	100	16	515	150	116.5	
						380	4									
MONA180	320-0.63	320	0.63	180	4×Φ6×12	220	6	1.4	134	17.9	100	16	515	150	116.5	
						380	4									
MONA180	320-1.0	320	1.0	180	4×Φ6×12	220	9	2.2	212	28.3	100	16	515	150	116.5	
						380	6									
MONA180	400-0.4	400	0.4	180	5×Φ6×12	220	7	1.1	85	11.3	120	16	515	150	116.5	
						380	4									
MONA180	400-0.5	400	0.5	180	5×Φ6×12	220	7	1.3	106	14.1	120	16	515	150	116.5	
						380	5									
MONA180	400-0.63	400	0.63	180	5×Φ6×12	220	7	1.8	134	17.9	130	16	515	150	116.5	
						380	5									
MONA180	400-1.0	400	1.0	180	5×Φ6×12	220	11	2.7	212	28.3	120	16	515	150	116.5	
						380	7									
MONA180	450-0.4	450	0.4	180	5×Φ6×12	220	8	1.2	85	11.3	140	16	515	150	116.5	
						380	5									
MONA180	450-0.5	450	0.5	180	5×Φ6×12	220	8	1.6	106	14.1	140	16	515	150	116.5	
						380	6									
MONA180	450-0.63	450	0.63	180	5×Φ6×12	220	8	2.0	134	17.9	140	16	515	150	116.5	
						380	6									
MONA180	450-1.0	450	1.0	180	5×Φ6×12	220	13	3.1	212	28.3	140	16	515	150	116.5	
						380	8									
MONA180	630-0.4	630	0.4	180	6×Φ6×12	220	11	1.7	85	11.3	190	16	585	220	116.5	
						380	7									
MONA180	630-0.5	630	0.5	180	6×Φ6×12	220	11	2.1	106	14.1	190	16	585	220	116.5	
						380	7									
MONA180	630-0.63	630	0.63	180	6×Φ6×12	220	11	2.7	134	17.9	190	16	585	220	116.5	
						380	7									
MONA180	630-1.0	630	1.0	180	6×Φ6×12	220	18	4.2	212	28.3	190	16	585	220	116.5	
						380	11									

注 Remark:

- 1、本机用于无机房。 The machine is used for machine roomless.
- 2、样本切口角为推荐值，可根据实际情况要求选择切口角度。 The above is recommended value of cut angle, it's optional according to practical condition.

90