

MGD100

Permanent Magnet Synchronous Gearless Traction Machine-Belt Type 永磁同步无齿轮钢带曳引机

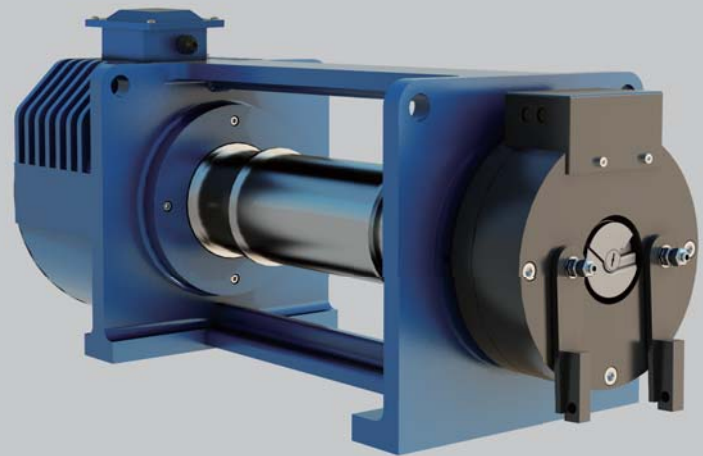

电源电压	Voltage	220V / 380V	曳引比	Roping	1:1 / 2:1
额定载重	Elv.Load	(320~630)kg	额定梯速	Elv.Speed	(0.4~1.0)m/s
钢带轮直径	Sheave Diam	100mm	工作制	Duty	S5-40%
防护等级	IP Code	IP41	最大轴静载	Max. Static Load	2500kg
绝缘等级	Ins.Class	F	自重	Weight	140kg
制动器	Brake	DC110V 1.8A			

※ 制动器的电压值表示启动及维持电压。 Brake voltage corresponds to its Start&Sustaining voltage.

安装尺寸图 DIMENSIONS

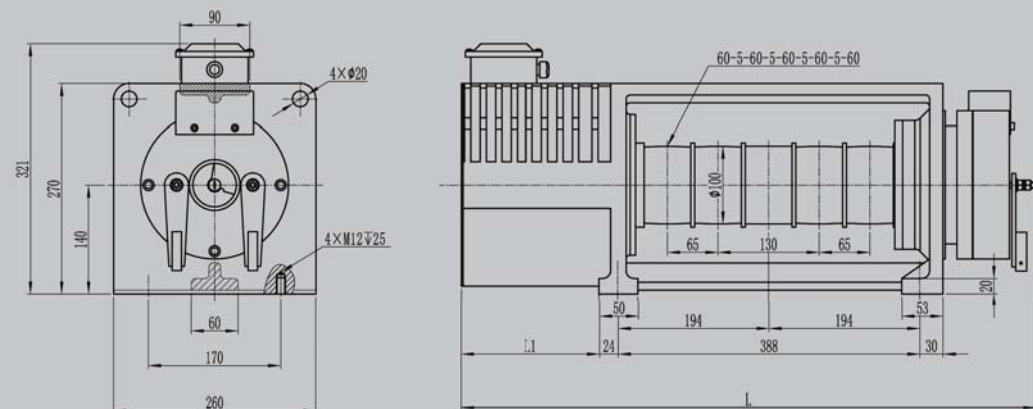

规格表 SPEC.SHEET

型号	规格	额定载重	额定梯速	钢带轮直径	钢带槽	电源电压	额定电流	额定功率	额定转速	额定频率	额定转矩	电机极数	L	L1
Type	Spec.	Elv. Load	Elv. Speed	Sheave Dia.	Groove	Voltage	Current	Power	Speed	Freq.	Torque	Poles	mm	mm
		kg	m/s	mm		V	A	kW	r/min	Hz	N·m			
Roping 曳引比 2:1														
MGD100	320-0.4	320	0.4	100	2×60	220/380	4	1.0	153	20.4	60	16	680.5	133
MGD100	320-0.5	320	0.5	100	2×60	220	7	1.2	191	25.5	60	16	680.5	133
						380	4							
MGD100	320-0.63	320	0.63	100	2×60	220	7	1.5	241	32.1	60	16	680.5	133
						380	4							
MGD100	320-1.0	320	1.0	100	2×60	220	9	2.4	382	50.9	60	16	680.5	133
						380	6							
MGD100	400-0.4	400	0.4	100	2×60	220/380	5	1.2	153	20.4	75	16	680.5	133
MGD100	400-0.5	400	0.5	100	2×60	220	8	1.5	191	25.5	75	16	680.5	133
						380	5							
MGD100	400-0.63	400	0.63	100	2×60	220	8	1.9	241	32.1	75	16	680.5	133
						380	5							
MGD100	400-1.0	400	1.0	100	2×60	220	12	3.0	382	50.9	75	16	680.5	133
						380	8							
MGD100	450-0.4	450	0.4	100	2×60	220	8	1.3	153	20.4	80	16	725.5	178
						380	5							
MGD100	450-0.5	450	0.5	100	2×60	220	8	1.6	191	25.5	80	16	725.5	178
						380	5							
MGD100	450-0.63	450	0.63	100	2×60	220	8	2.0	241	32.1	80	16	725.5	178
						380	5							
MGD100	450-1.0	450	1.0	100	2×60	220	12	3.2	382	50.9	80	16	725.5	178
						380	8							
MGD100	630-0.4	630	0.4	100	3×60	220	11	1.8	153	20.4	110	16	725.5	178
						380	7							
MGD100	630-0.5	630	0.5	100	3×60	220	11	2.2	191	25.5	110	16	725.5	178
						380	7							
MGD100	630-0.63	630	0.63	100	3×60	220	11	2.8	241	32.1	110	16	725.5	178
						380	7							
MGD100	630-1.0	630	1.0	100	3×60	220	16	4.4	382	50.9	110	16	725.5	178
						380	11							
Roping 曳引比 1:1														
MGD100	320-0.3	320	0.3	100	2×60	220	6	0.7	57	7.6	110	16	725.5	178
						380	4							
MGD100	320-0.4	320	0.4	100	2×60	220	6	0.9	76	10.1	110	16	725.5	178
						380	4							
MGD100	400-0.3	400	0.3	100	2×60	220	7	0.8	57	7.6	130	16	725.5	178
						380	5							
MGD100	400-0.4	400	0.4	100	2×60	220	7	1.0	76	10.1	130	16	725.5	178
						380	5							

注 Remark:

1、本机用于无机房。 The machine is used for machine roomless.