

MGD87

Permanent Magnet Synchronous Gearless Traction Machine-Belt Type
 永磁同步无齿轮钢带曳引机

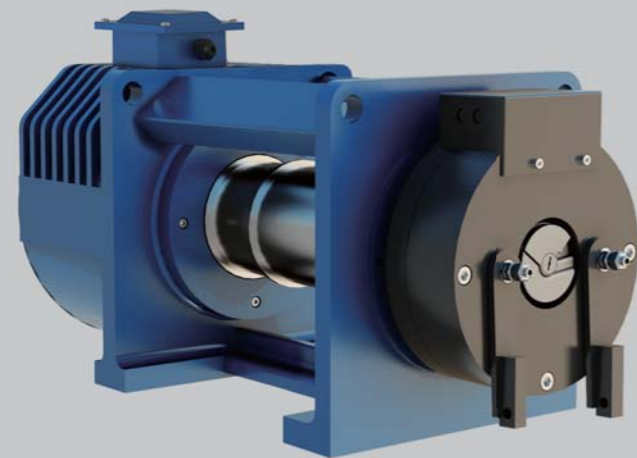

电源电压	Voltage	220V / 380V	曳引比	Roping	2:1
额定载重	Elv.Load	(320~450)kg	额定梯速	Elv.Speed	(0.4~1.0)m/s
钢带轮直径	Sheave Diam	87mm	工作制	Duty	S5-40%
防护等级	IP Code	IP41	最大轴静载	Max. Static Load	2000kg
绝缘等级	Ins.Class	F	自重	Weight	80kg
制动器	Brake	DC110V 1.8A			

※ 制动器的电压值表示启动及维持电压。 Brake voltage corresponds to its Start&Sustaining voltage.

安装尺寸图 DIMENSIONS

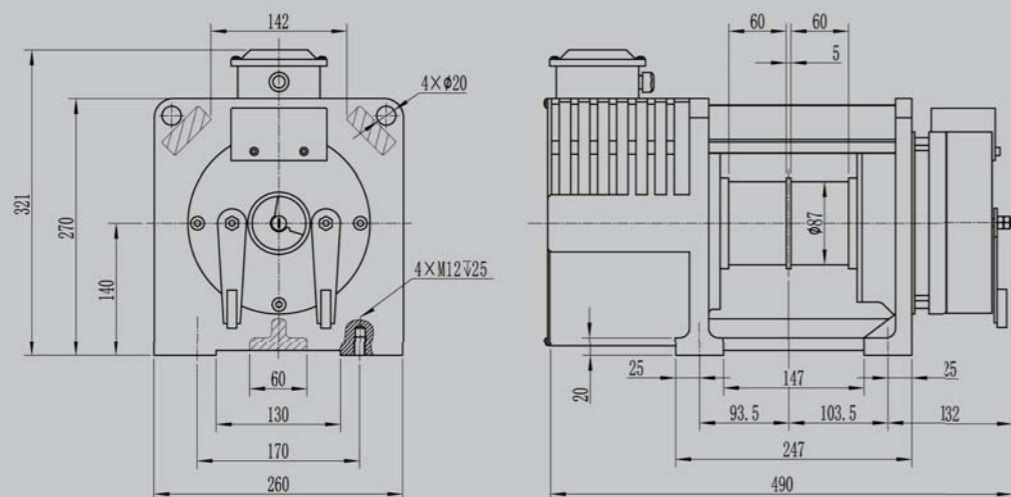

规格表 SPEC.SHEET

型号	规格	额定载重	额定梯速	钢带轮直径	钢带槽	电源电压	额定电流	额定功率	额定转速	额定频率	额定转矩	电机极数
Type	Spec.	Elv. Load	Elv. Speed	Sheave Dia.	Groove	Voltage	Current	Power	Speed	Freq.	Torque	Poles
		kg	m/s	mm		V	A	kW	r/min	Hz	N·m	
MGD87	320-0.4	320	0.4	87	2×60	220/380	4	1.0	176	23.5	55	16
MGD87	320-0.5	320	0.5	87	2×60	220	7	1.3	220	29.3	55	16
						380	4					
MGD87	320-0.63	320	0.63	87	2×60	220	7	1.6	277	36.9	55	16
						380	4					
MGD87	320-1.0	320	1.0	87	2×60	220	10	2.5	439	58.5	55	16
						380	7					
MGD87	400-0.4	400	0.4	87	2×60	220/380	5	1.2	176	23.5	65	16
MGD87	400-0.5	400	0.5	87	2×60	220	8	1.5	220	29.3	65	16
						380	5					
MGD87	400-0.63	400	0.63	87	2×60	220	8	1.9	277	36.9	65	16
						380	5					
MGD87	400-1.0	400	1.0	87	2×60	220	12	3.0	439	58.5	65	16
						380	8					
MGD87	450-0.4	450	0.4	87	2×60	220/380	6	1.4	176	23.5	75	16
MGD87	450-0.5	450	0.5	87	2×60	220	9	1.7	220	29.3	75	16
						380	6					
MGD87	450-0.63	450	0.63	87	2×60	220	9	2.2	277	36.9	75	16
						380	6					
MGD87	450-1.0	450	1.0	87	2×60	220	14	3.4	439	58.5	75	16
						380	9					

注 Remark:

1、本机用于无机房。 The machine is used for machine roomless.