

MDD710

Permanent Magnet Synchronous Gearless Traction Machine
永磁同步无齿轮曳引机

MDD710

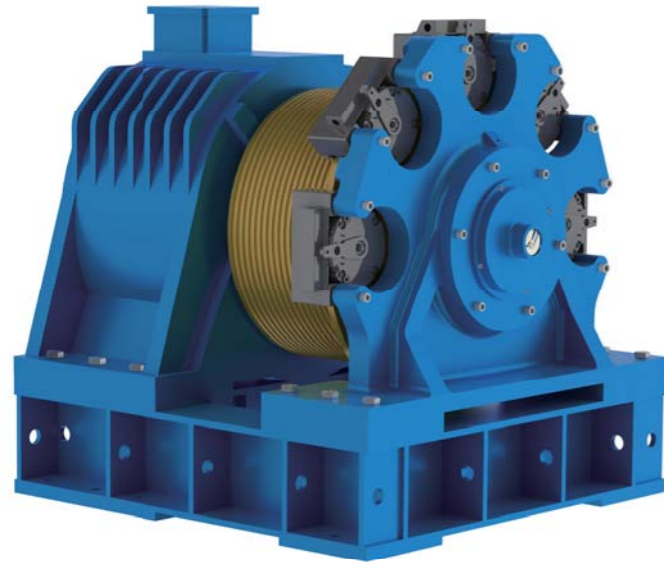

电源电压	Voltage	380V
曳引比	Roping	1:1
额定载重	Elv. Load	(1600~2000)kg
额定梯速	Elv. Speed	(5.0~8.0)m/s
曳引轮节径	Sheave Diam	710mm
防护等级	IP Code	IP41
绝缘等级	Ins. Class	F
最大轴静载	Max. Static Load	40000kg
工作制	Duty	S5-40%
自重	Weight	3500kg
制动器	Brake	AC220V 5×2.2A

安装尺寸图 DIMENSIONS

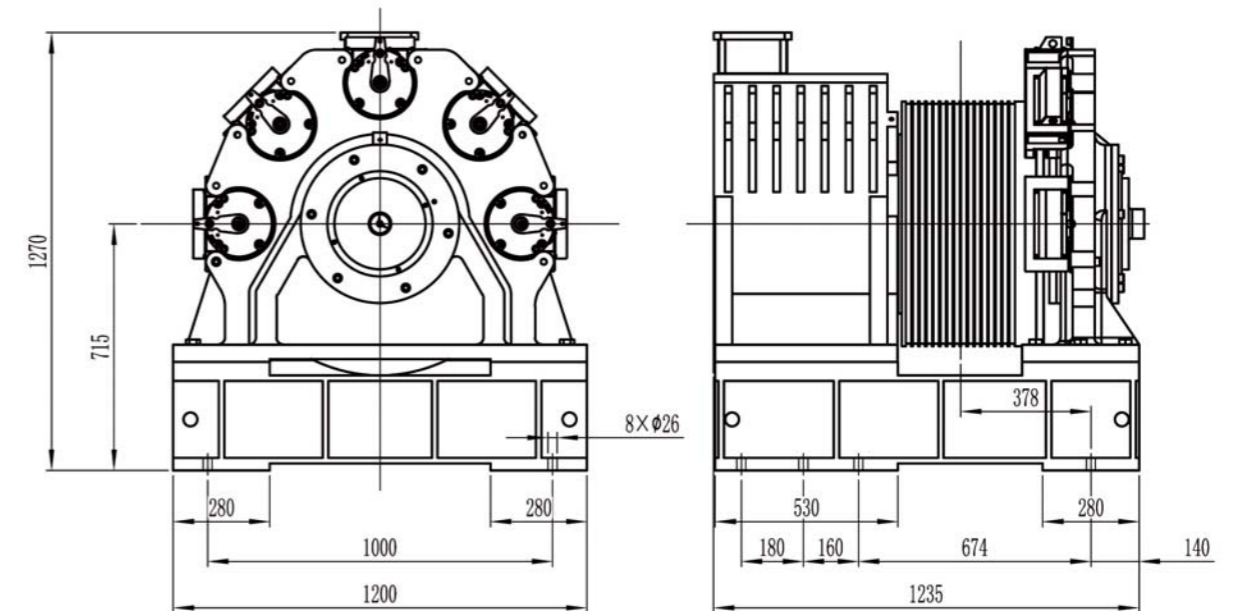

规格表 SPEC. SHEET

型号	规格	额定载重	额定梯速	曳引轮节径	曳引轮绳槽	绕绳方式	额定电流	额定功率	额定转速	额定频率	额定转矩	电机极数
Type	Spec.	Elv. Load	Elv. Speed	Sheave Dia.	Sheave Groove	Wrap	Current	Power	Speed	Freq.	Torque	Poles
		kg	m/s	mm			A	kW	r/min	Hz	N·m	
MDD710	1600-5.0	1600	5.0	710	16×Φ16×20	复绕(Double)	108	52.6	134	35.7	3750	32
MDD710	1600-6.0	1600	6.0	710	16×Φ16×20	复绕(Double)	135	63.2	161	42.9	3750	32
MDD710	1600-7.0	1600	7.0	710	16×Φ16×20	复绕(Double)	150	73.8	188	50.1	3750	32
MDD710	1600-8.0	1600	8.0	710	16×Φ16×20	复绕(Double)	175	84.4	215	57.3	3750	32
MDD710	2000-5.0	2000	5.0	710	16×Φ16×20	复绕(Double)	135	65.9	134	35.7	4700	32
MDD710	2000-6.0	2000	6.0	710	16×Φ16×20	复绕(Double)	167	79.2	161	42.9	4700	32
MDD710	2000-7.0	2000	7.0	710	16×Φ16×20	复绕(Double)	190	92.5	188	50.1	4700	32
MDD710	2000-8.0	2000	8.0	710	16×Φ16×20	复绕(Double)	218	105.8	215	57.3	4700	32

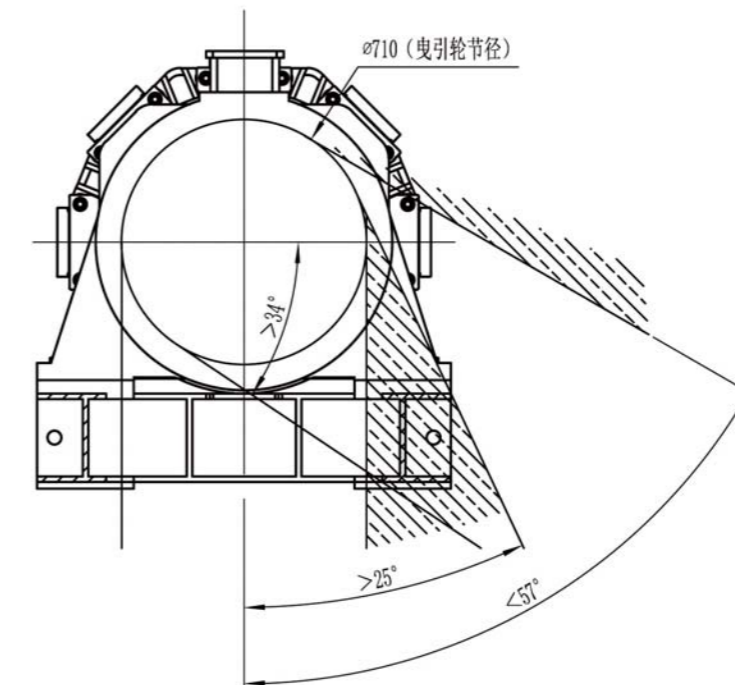

注 Remark:
钢丝绳绕出角度按图示部分, 避开阴影范围。
The angle of wire rope shall be within the range shown as above, while avoiding the shadow part.