

# MDD640

Permanent Magnet Synchronous Gearless Traction Machine

永磁同步无齿轮曳引机

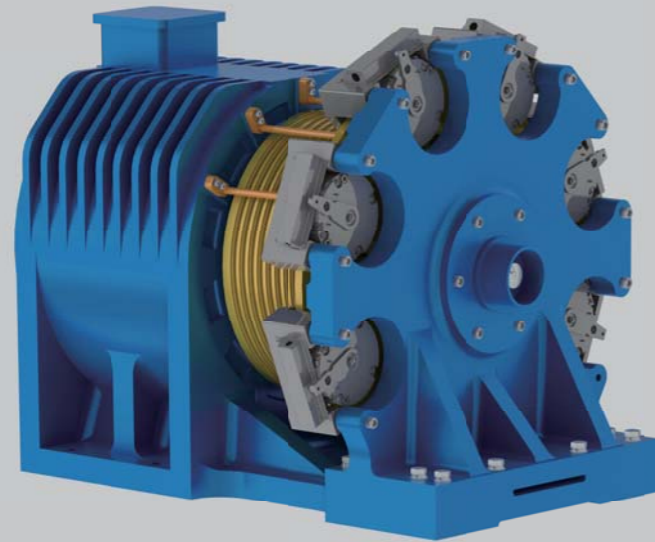

电源电压	Voltage	380V	曳引比	Roping	1:1 / 2:1
额定载重	Elv.Load	(3500~5200)kg	额定梯速	Elv.Speed	(0.5~1.5)m/s
钢带轮直径	Sheave Diam	640mm	工作制	Duty	S5-40%
防护等级	IP Code	IP41	最大轴静载	Max. Static Load	20000kg
绝缘等级	Ins.Class	F	自重	Weight	2600kg
制动器	Brake	AC220V 6×2.2A			

安装尺寸图 DIMENSIONS

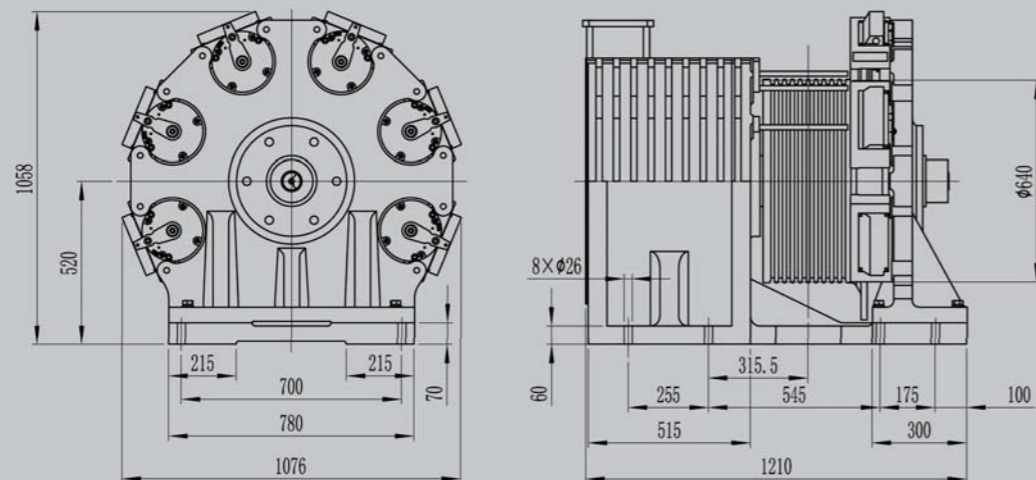

## 规格表 SPEC.SHEET

型号	规格	额定载重	额定梯速	曳引轮节径	曳引轮绳槽	额定电流	额定功率	额定转速	额定频率	额定转矩	电机极数	切口角
Type	Spec.	Elv. Load	Elv. Speed	Sheave Dia.	Sheave Groove	Current	Power	Speed	Freq.	Torque	Poles	β Angle
		kg	m/s	mm		A	kW	r/min	Hz	N·m		°
Roping 曳引比 2:1												
MDD640	3500-0.5	3500	0.5	640	7×Φ16×25	35	11.4	30	10.0	3640	40	
MDD640	3500-0.75	3500	0.75	640	7×Φ16×25	54	17.2	45	15.0	3640	40	
MDD640	3500-1.0	3500	1.0	640	7×Φ16×25	54	22.9	60	20.0	3640	40	
MDD640	3500-1.5	3500	1.5	640	7×Φ16×25	87	34.3	90	30.0	3640	40	
MDD640	4000-0.5	4000	0.5	640	8×Φ16×25	40	13.1	30	10.0	4160	40	
MDD640	4000-0.75	4000	0.75	640	8×Φ16×25	62	19.6	45	15.0	4160	40	
MDD640	4000-1.0	4000	1.0	640	8×Φ16×25	62	26.1	60	20.0	4160	40	
MDD640	4000-1.5	4000	1.5	640	8×Φ16×25	99	39.2	90	30.0	4160	40	95
MDD640	4500-0.5	4500	0.5	640	8×Φ16×25	45	14.7	30	10.0	4680	40	
MDD640	4500-0.75	4500	0.75	640	8×Φ16×25	70	22.1	45	15.0	4680	40	
MDD640	4500-1.0	4500	1.0	640	8×Φ16×25	70	29.4	60	20.0	4680	40	
MDD640	4500-1.5	4500	1.5	640	8×Φ16×25	111	44.1	90	30.0	4680	40	
MDD640	5200-0.5	5200	0.5	640	9×Φ16×25	50	17.0	30	10.0	5400	40	
MDD640	5200-0.75	5200	0.75	640	9×Φ16×25	78	25.4	45	15.0	5400	40	
MDD640	5200-1.0	5200	1.0	640	9×Φ16×25	78	33.9	60	20.0	5400	40	
MDD640	5200-1.5	5200	1.5	640	9×Φ16×25	132	50.9	90	30.0	5400	40	
Roping 曳引比 1:1												
MDD640	1800-1.0	1800	1.0	640	7×Φ16×25	36	11.7	30	10.0	3740	40	
MDD640	1800-1.5	1800	1.5	640	7×Φ16×25	56	17.6	45	15.0	3740	40	
MDD640	1800-1.75	1800	1.75	640	7×Φ16×25	56	20.4	52	17.3	3740	40	
MDD640	1800-2.0	1800	2.0	640	7×Φ16×25	56	23.5	60	20.0	3740	40	
MDD640	2000-1.0	2000	1.0	640	8×Φ16×25	40	13.1	30	10.0	4160	40	
MDD640	2000-1.5	2000	1.5	640	8×Φ16×25	62	19.6	45	15.0	4160	40	
MDD640	2000-1.75	2000	1.75	640	8×Φ16×25	62	22.7	52	17.3	4160	40	95
MDD640	2000-2.0	2000	2.0	640	8×Φ16×25	62	26.1	60	20.0	4160	40	
MDD640	2500-1.0	2500	1.0	640	9×Φ16×25	50	16.3	30	10.0	5200	40	
MDD640	2500-1.5	2500	1.5	640	9×Φ16×25	78	24.5	45	15.0	5200	40	
MDD640	2500-1.75	2500	1.75	640	9×Φ16×25	78	28.3	52	17.3	5200	40	
MDD640	2500-2.0	2500	2.0	640	9×Φ16×25	78	32.7	60	20.0	5200	40	

注 Remark:

1、本机型切口角度 $\gamma=15^\circ$ 。The undercut angle of the machine is  $15^\circ$ .